

THIS DRAWING IS UNPUBLISHED. RELEASED FOR PUBLICATION  
 © COPYRIGHT - By - ALL RIGHTS RESERVED.

LOC		DIST		REVISIONS			
P	LTR	DESCRIPTION		DATE	DWN	APVD	
CM	00	P1		REVISED PER ECO-11-004587	11MAR11	RK	HMR

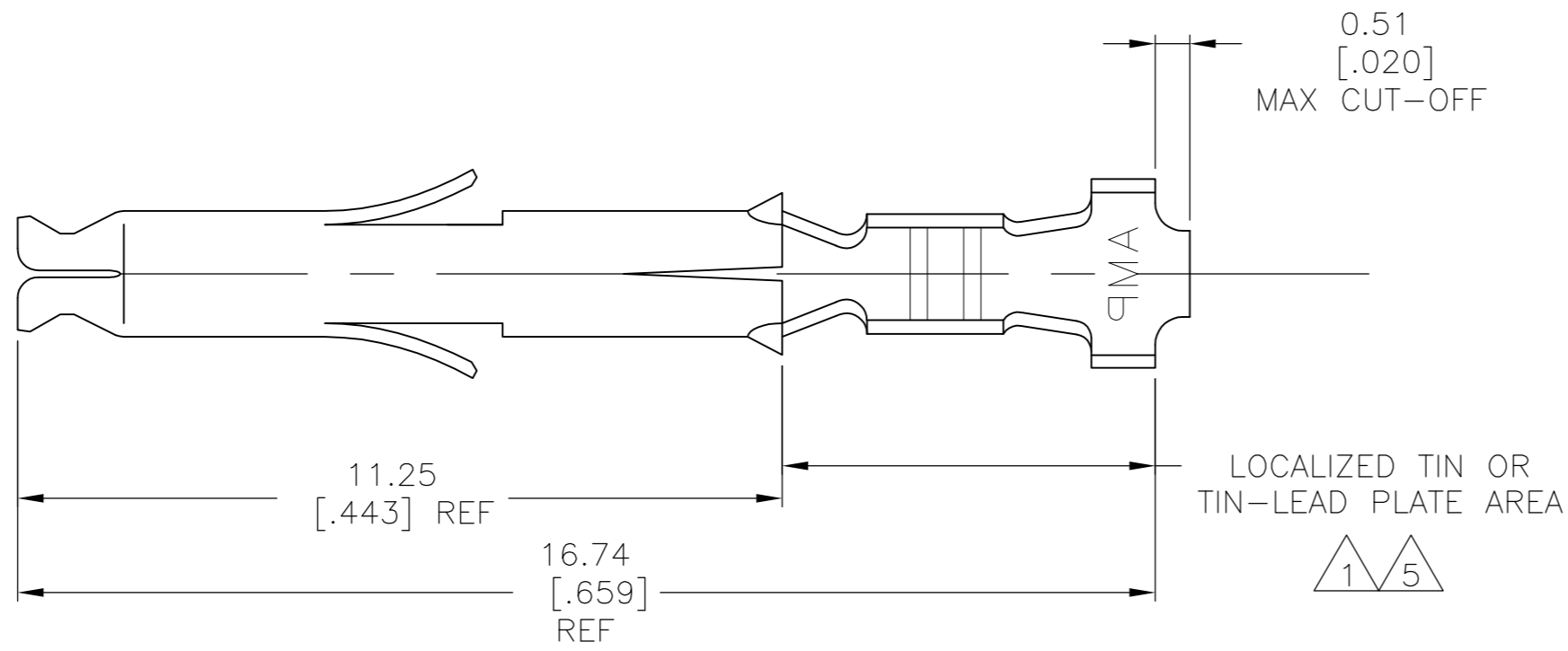

- 1 0.00076 [.000030] MIN GOLD IN LOCALIZED GOLD PLATE AREA AND 0.00254 [.000100] MIN BRIGHT TIN-LEAD IN LOCALIZED TIN-LEAD PLATE AREA OVER 0.00130 [.000050] MIN NICKEL.
- 2 WIRE RANGE: 0.12 - 0.4mm<sup>2</sup> (26-22 AWG).
- 3 INSULATION RANGE: 1.20-1.75[.047-.069] DIA.
- 4 DIMENSIONS IN BRACKETS ARE IN INCHES.
- 5 0.00076 [.000030] MIN GOLD IN LOCALIZED GOLD PLATE AREA AND 0.00254 [.000100] MIN BRIGHT TIN IN LOCALIZED TIN PLATE AREA OVER 0.00130 [.000050] MIN NICKEL.

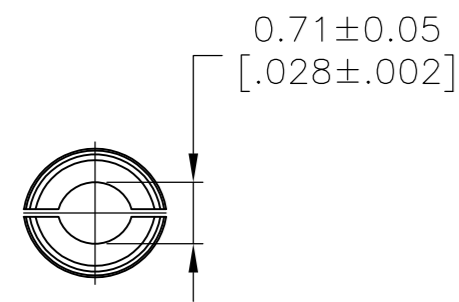
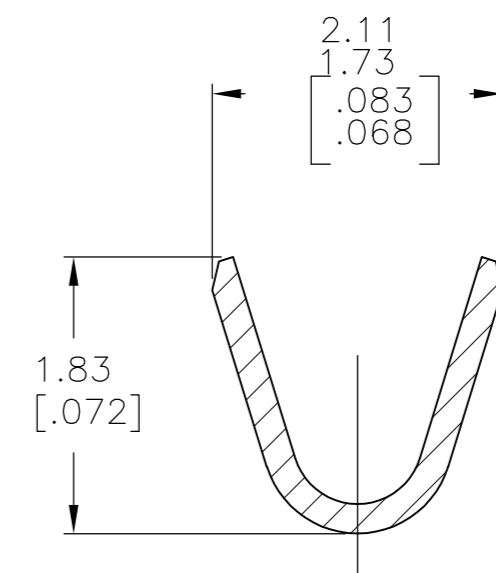
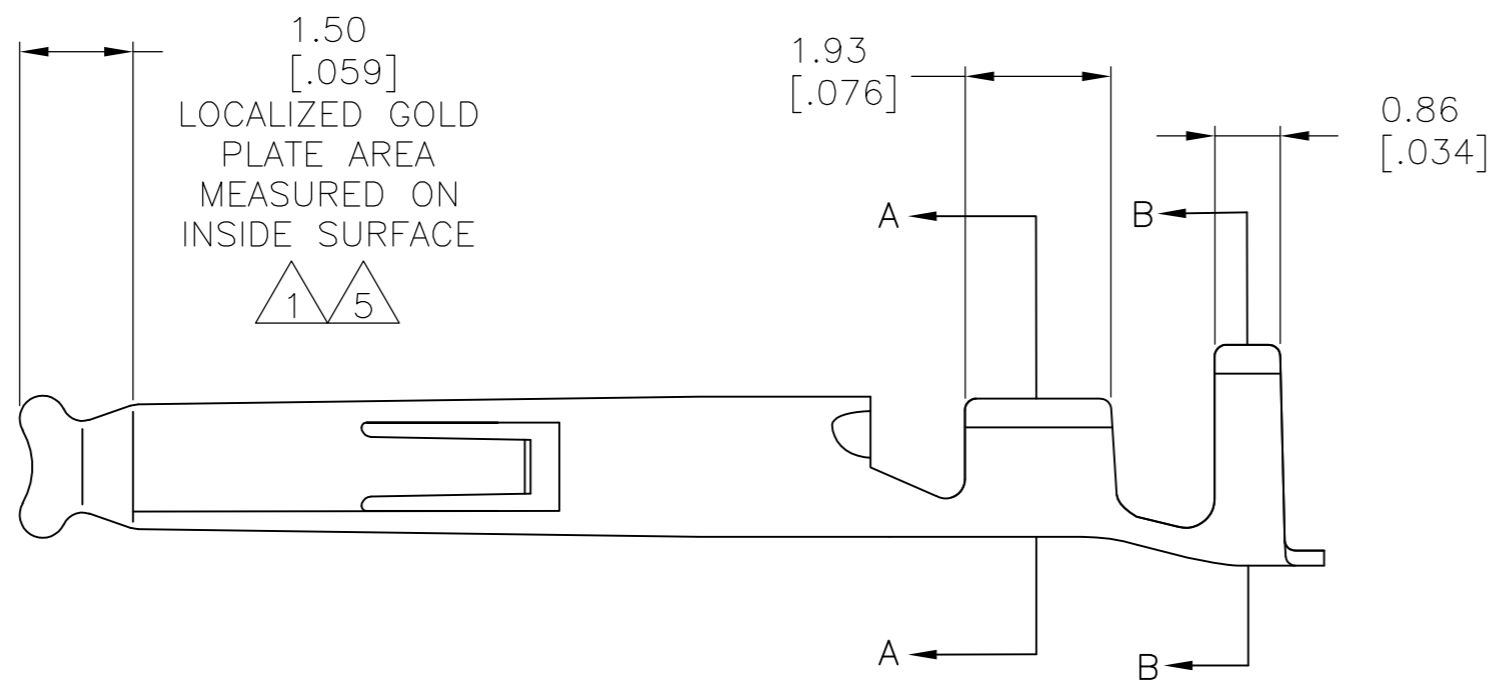

SECTION A-A  
SCALE 20:1

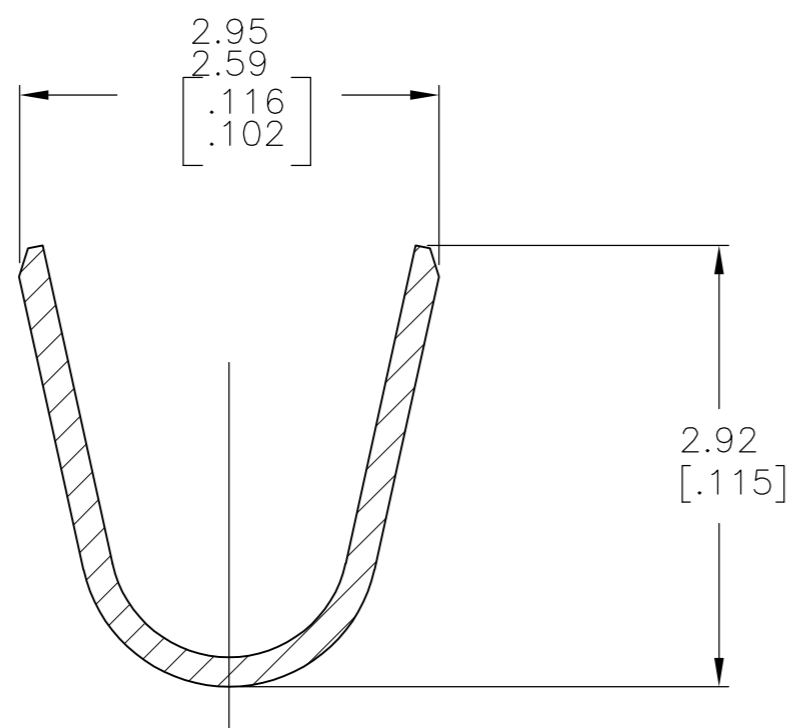

SECTION B-B  
SCALE 20:1

5	0.20 [.008] PH BRZ	1-770902-1
5	0.20 [.008] BRASS	1-770902-0
1	0.20 [.008] PH BRZ	770902-6
PRE-TIN	0.20 [.008] PH BRZ	770902-4
1	0.20 [.008] BRASS	770902-3
PRE-TIN	0.20 [.008] BRASS	770902-1
FINISH	MATERIAL	PART NUMBER

THIS DRAWING IS A CONTROLLED DOCUMENT.		DWN S. HOOVER 16OCT02	TE Connectivity	
DIMENSIONS: mm [INCHES]		CHK C. JONES 16OCT02		
TOLERANCES UNLESS OTHERWISE SPECIFIED:		APVD C. JONES 16OCT02	NAME SOCKET, MINI UNIVERSAL MATE-N-LOK(TM)	
0 PLC ± -		PRODUCT SPEC	SIZE A2	
1 PLC ± -		APPLICATION SPEC	CAGE CODE 00779	
2 PLC ± -		WEIGHT	DRAWING NO C=770902	
3 PLC ± 0.15[.006]		RESTRICTED TO	-	
4 PLC ± -		CUSTOMER DRAWING	SCALE 10:1 SHEET 1 of 1 REV P1	
ANGLES ± 1°				
FINISH				